



CMC S19 N:
“N” is the most compact crawler access platform available in this size range with the shortest stabilizing width area, less than 10,2 m²!

The CMC S19 N is a narrow tracked boom lift. It is ultra-compact and user friendly, with intuitive controls and no fuss. The S19N can pass through a single doorway and operate in the tightest space. Once setup, the impressive height and outreach is achieved with a limiting device of last generation. The maximum basket capacity is 230 kg.



REV 3.17 artimedia





Single Doorway width (780 mm)



Towable Transportable



Electro-hydraulic proportional controls



OPTIONAL Hydraulic extending tracks

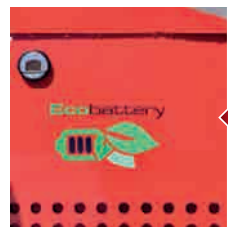

OPTIONAL Eco Battery



OPTIONAL Kubota Diesel Engine



OPTIONAL Dual Voltage AC Motor



Simple to use

User-friendly, with intuitive 4-step operation from start to working at height.

Power options

Honda GX 390 gasoline engine. As optional: Kubota Z842 diesel engine, electric engine of 220V or 120V or 110V, lithium power batteries with electric motor.

Service friendly

Simple operating system with fault code diagnosis and easy to repair on-site.

Narrow

N stands for Narrow, this is the spiderlift with the narrowest stabilization area, only 3m² for 19m of height.

Versatile

Built with a double pantograph lower boom, articulated upper boom with one telescopic boom extension, plus an articulating jib. With innovative basket design, offers unrivaled performance.

Towable transportable

Low weight and very compact, so suitable to tow on a trailer behind mid-size vans and 4x4 vehicles.

PERFORMANCE

Max working height	18,8 m
Max working outreach (with <= 120 Kg)	9,2 m
Max load on the basket	230 kg
Jib movement	90°
Turret rotation	± 178° (TOT. 356°)
Basket rotation	N.A.
P Max slope to stabilize	5°/ 9%
Tracks enlargement (optional)	0,30 m
W Max ramp slope (attack)	16°/29%
X Max slope to travel	20°/36%
Max travel speed	0,57/1,07 Km/h

DIMENSIONS

A Basket height	1,10 m
B Basket width	0,70 m
C Basket length	1,20 m
D Total length	5,12 m
E Total length without basket	4,48 m
F Height in driving position	1,97 m
G Total width (without basket)	0,78 m
H Free height from the ground	0,23 m
I Tracks (LxP)	1,44 x 0,18 m
J Max longitudinal stabilization	3,58 m
K Max cross stabilization	2,84 m
Stabilizers plate Ø	0,18 m

WEIGHTS

Total weight	2.600 kg/5.732 lb (Honda) 2.600 kg/5.732 lb (Kubota)
R Max pressure on the foot	6,3 kg/cm ² - 61,8 N/cm ²
S Max pressure on the track	0,87 kg/cm ² - 8,5 N/cm ²
T Max pressure in travel	313 kg/ m ² - 3,07 N/m ²
U Max pressure in work	205 kg/ m ² - 2,01 N/m ²

POWER

Standard power	
Gasoline	Honda GX390 (6,0 kW)
Fuel tank capacity	6,1L

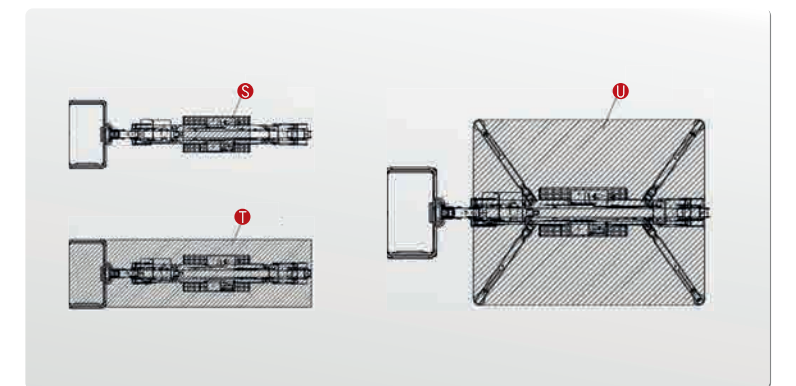
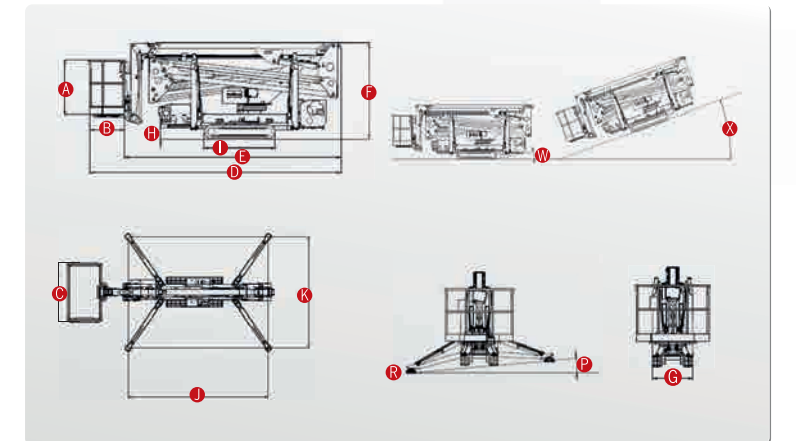

MAX LOAD 230 kg/507 lb 120 kg/265 lb

