

**Junttan**

Powerpack  
10XCU

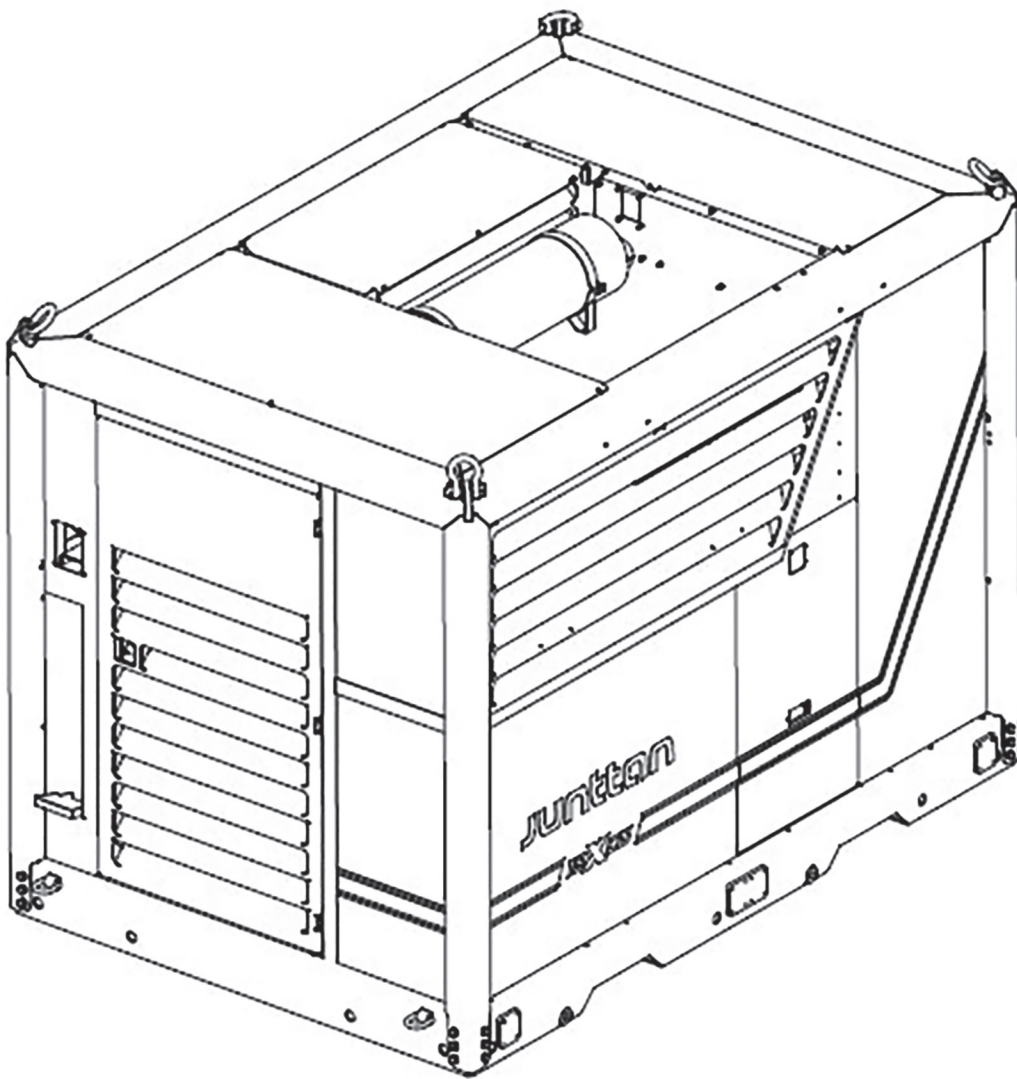

Original  
Junttan  
product

**DATA SHEET**

# Technical Data

## Basic Features

Nominal operational weight	5 500 kg	12 120 lb
Engine type	Cummins QSC8.3	Tier3 / Stage3A
Rated Power	227 kW	305 hp
Maximum Power	248 kW	333 hp
Engine type	Cummins QSL9	Tier4i / Stage3B
Rated Power	239 kW	320 hp
Maximum Power	254 kW	340 hp
Max operating hyd pressure	350 bar	5 076 psi
Hydraulic Oil flow max.	380 l/min @ 2 000 rpm	100 qpm @ 2 000 rpm
Hydraulic oil reservoir	1 000 liters	263 gal
Fuel Capacity	660 liters	173 gal
Control system	X-control (pile cruise)	

## Suitable Junttan Hammers

SHK9 and smaller

## Accessories

- \* Arctic kit (Heats: batteries, engine, hydraulic oil)
- \* Tropical kit (Extra cooler for hydraulic oil)
- \* Working platforms
- \* Vacuum pump (Hydraulic system)

## Dimensions

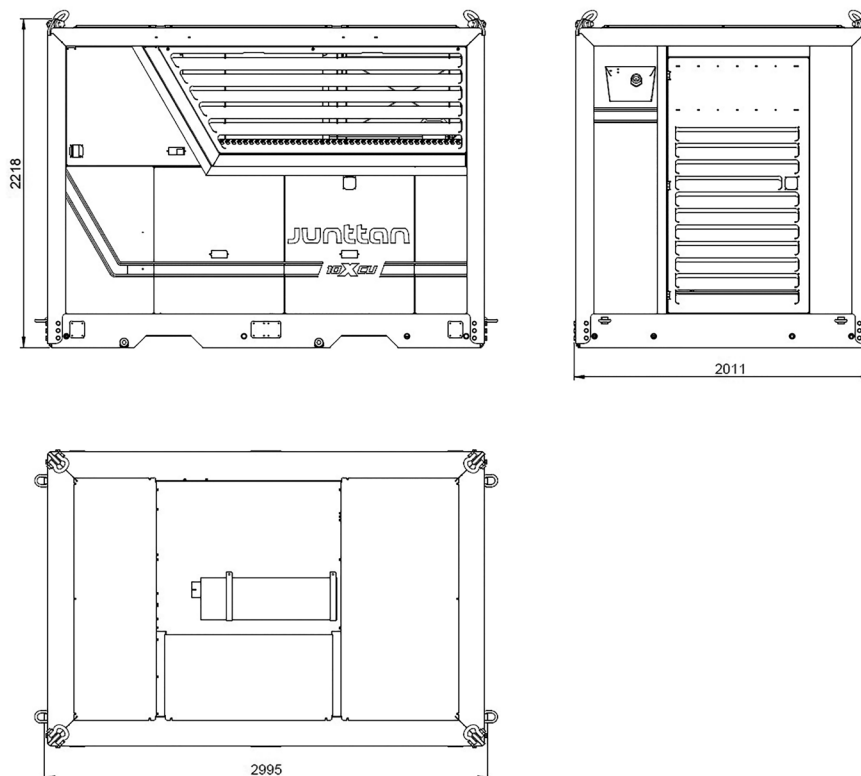

**Junttan**

**Junttan Oy**  
 P.O. Box 1702 (Matkuksentie 7)  
 FI-70701 KUOPIO, Finland

Tel. +358 10 195 221  
 Fax +358 17 287 4411  
[junttan@junttan.com](mailto:junttan@junttan.com)